

ECON FP SERIES SPECIFICATIONS

STENNER PUMPS®



C USA
 THIS PUMP IS TESTED AND CERTIFIED BY NQA ACCORDING TO ANSINFS 51 FOR CONTACT WITH SODIUM HYPOCHLORITE AND WATER ONLY AND ANSINFS 372.

UL US
LISTED
 METERING PUMP
 96FO
CE IP44

SHIPPING WEIGHT 4 lbs (1.7 kg)

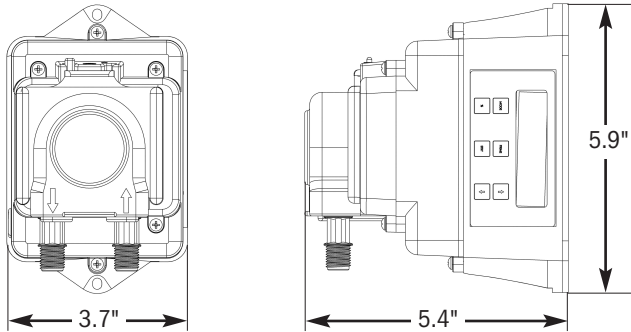

FEATURES

- Pump is field programmable to accept a dry contact signal or a 12-24 VAC/VDC input signal from any control equipment that responds to flow
- cULus for indoor/outdoor use
- 3-point roller design assists in anti-siphon protection
- Pump head requires no valves, allows for easy maintenance
- Self-priming against maximum working pressure, foot valve not required
- Pump does not lose prime or vapor lock
- Pumps off-gassing solutions and can run dry
- Output volume is not affected by back pressure
- Easy to change pump tube; lubrication is not required

FLOW RATE OUTPUT CONTROL Six button control panel with LCD display
REPRODUCIBILITY ±2%

MAXIMUM WORKING PRESSURE 80 psi (5.5 bar)

MAXIMUM OPERATING TEMPERATURE 104°F (40°C)

MAXIMUM SUCTION LIFT 25 ft (7.6 m) vertical lift, based on water

MOTOR TYPE 240VDC, brushless

SHAFT RPM (average maximum) 60

DUTY CYCLE Continuous

MOTOR VOLTAGE (Amp Draw) 120V 60Hz, 240V 50Hz (0.17)

EXTERNAL POWER SUPPLY 100-120VAC, 60Hz or 220-240VAC, 50Hz

POWER CORD TYPE 120V 60Hz, 240V 50Hz: STP-2W

POWER CORD LENGTH 6 ft (1.83 m), 10 ft (3.05 m)

POWER CORD PLUG END

Wall adapter, Class II power supply: 100-120V 60Hz: 1.0A maximum input, two prong, polarized 24VDC, 1.25A output or 220-240V 50Hz: 1.0A maximum input, two prong, CEE7 style plug 24VDC 1.87A output

CLASSIFICATION Indoor/outdoor

MATERIALS OF CONSTRUCTION

All Housings Polycarbonate

Pump Tube & Check Valve Duckbill Santoprene®, FDA approved

Pump Head Rollers Polyethylene

Suction/Discharge Tubing, Ferrules Polyethylene, FDA approved

Tube and Injection Fittings PVC or Polypropylene, NSF listed

Connecting Nuts PVC, NSF listed

Suction Line Strainer and Cap PVC or Polypropylene, NSF listed, with Ceramic Weight

All Fasteners Stainless steel

* Santoprene® is a trademark of Exxon Mobil Corporation.

ACCESSORY KIT SHIPPED WITH EACH PUMP

3 Connecting nuts 1/4"

3 Ferrules 1/4" or 6 mm *Europe*

1 Injection check valve

1 Weighted suction line strainer 1/4" or 6 mm *Europe*

1 20' Roll suction/discharge tubing 1/4" white or UV black OR 6 mm White *Europe*

1 Additional pump tube

1 Manual

FLOW RATE OUTPUT CHART

80 psi (5.5 bar) maximum

Item Number Prefix	Pump Tube	Roller Assembly	Turndown Ratio	Gallons per Day	Gallons per Hour	Ounces per Hour	Ounces per Minute	Liters per Day	Liters per Hour	Milliliters per Hour	Milliliters per Minute
E10PLM	M	White	10:1	0.49	0.02	2.6	0.04	1.84	0.08	76.7	1.3
E10PHM	M	White	10:1	0.83	0.03	4.4	0.07	3.14	0.13	130.8	2.2
E20PHM	M	White	10:1	1.41	0.06	7.5	0.13	5.36	0.22	223.2	3.7
E20PHF	F	White	10:1	4.5	0.19	24.0	0.40	17.01	0.71	708.8	11.8
E20PHG	G	Black	10:1	16.0	0.67	85.3	1.42	60.48	2.52	2520.0	42.0
E20PHH	H	Black	10:1	30.0	1.25	160.0	2.67	113.40	4.73	4725.0	78.8

Approximate Maximum Output @ 50/60Hz

NOTE: Injection check valve included with pumps rated 80 psi (5.5 bar) maximum.

NOTICE: The information within this chart is solely intended for use as a guide. The output data is an approximation based on pumping water under a controlled testing environment. Many variables can affect the output of the pump. Stenner Pump Company recommends that all metering pumps undergo field calibration by means of analytical testing to confirm their outputs.