

# First choice in agricultural ventilation components

## WARRANTY

TPI Polytechnics Inc. offers a 2 year warranty on manufacturers defects. This warranty covers any defects caused by faulty production or design flaws. For parts that are designed to move, wear and tear there is no warranty as these parts are intended and designed to be replaceable. To find details on which parts are marked as replaceable please contact TPI Polytechnics Inc. for further information.

Since TPI Polytechnics Inc. products are meant to be installed by professionals there is no warranty over installation mishaps or any damage caused by incorrect installation of the products herein.

TPI Polytechnics does offer a service warranty of 2 years over correctly and professionally installed products, therefore we strongly advise to use professional personnel.

When in doubt, feel free to contact TPI Polytechnics Inc. to ask for qualified personnel in your area.

Our polyurethane formula guarantees high insulation values but does not in any case guarantee that products cannot freeze when in low temperatures. To ensure optimal functioning of your product(s) please contact your dealer or TPI Polytechnics Inc. for information on installation, set-up, adjustments and functionality.

Please note that under no circumstance TPI Polytechnics Inc. can be held responsible for loss of life or any type of injury both to humans and animals due to malfunction of our product(s)!

## TPI Polytechnics Inc.

420 N Iris St  
Mt. Pleasant, IA 52641  
United States

T +31 (0)73 - 656 91 94  
info@tpi-polytechnics.com



# 1800-VFG-C

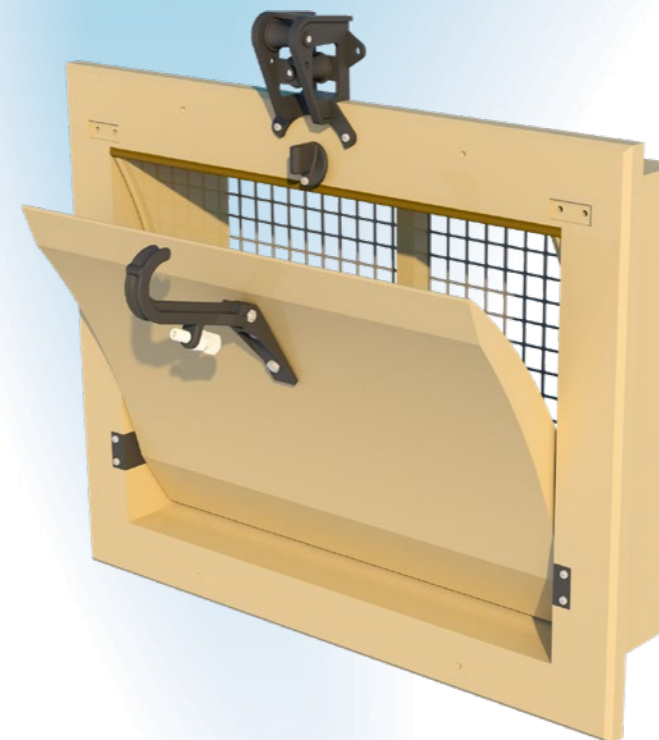

The 1800-VFG-C air inlet valve is made entirely out of high-quality polyurethane. The 1800-VFG-C has a curved inner flap which is hinged in the middle of the house, so when the inner flap opens further then 35% the air also flows underneath the flap. The inlet is controlled by means of a central plastic arm.

## CAPACITY

Capacity in CFM at a static pressure of inch H2O:

Model	0.05	0.10	0.15
1800-VFG-C	1182	1670	2046

## WHAT'S IN THE BOX

1800-VFG-C air inlet valve	-	23Pcs.
Central plastic control arm	TPI-280	23Pcs.
Nylon cord and cable clamp	TPI-204c	23Pcs.
Pulley unit	TPI-421	23Pcs.
Closing catch with spring	TPI-307	23Pcs.

## INFORMATION

Run	21.6 Inch
Force	14.7 Newtons
Number / pallet (3.94 x 3.28 x 7.87 ft)	46 (2 boxes)

## AIR FLOW

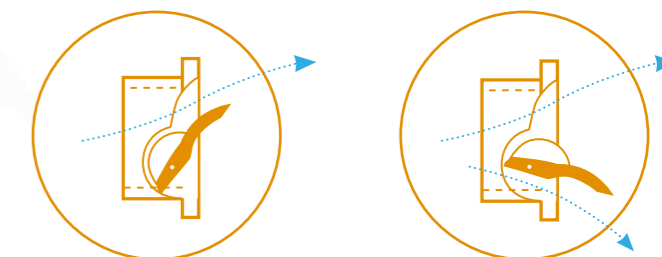

**POSITION IN WALL**

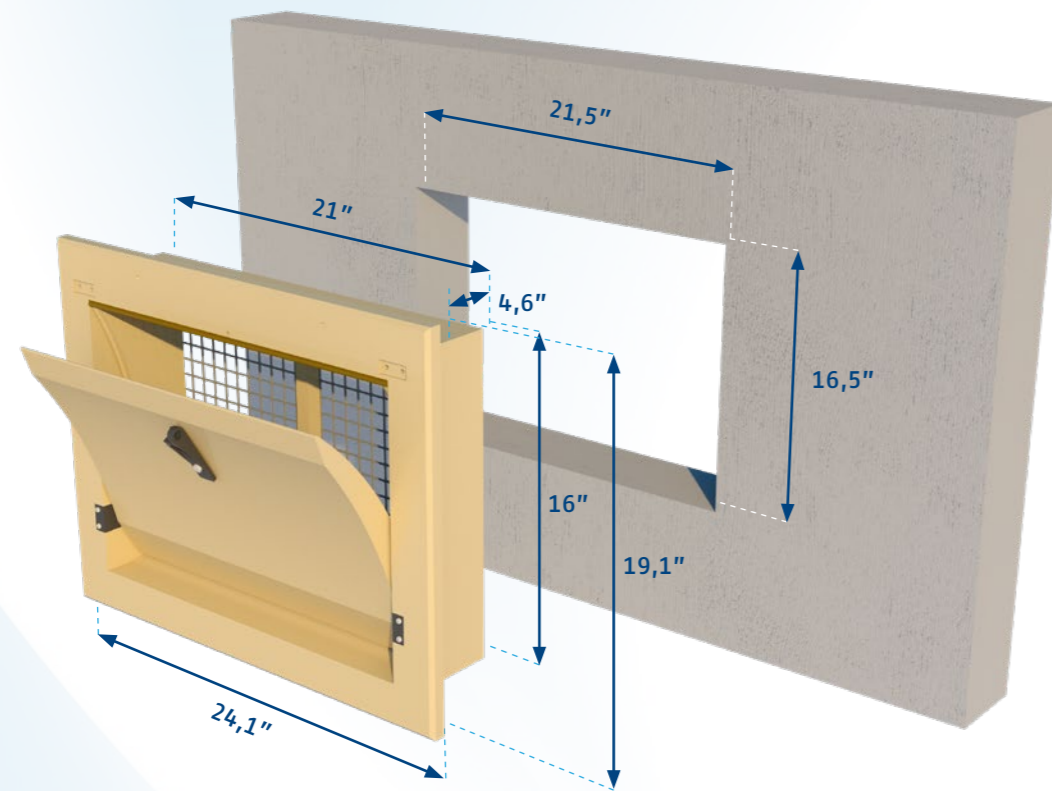

**MOUNTING**

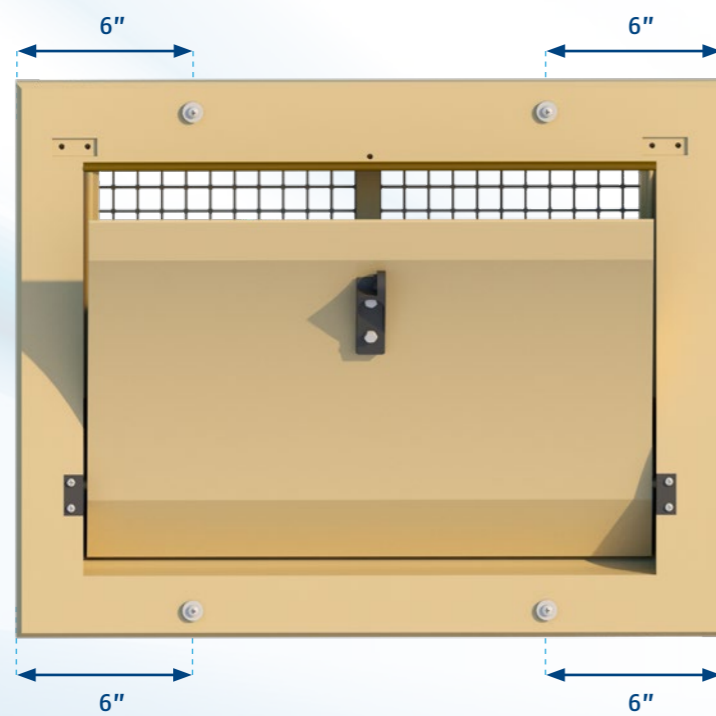

**ASSEMBLY**

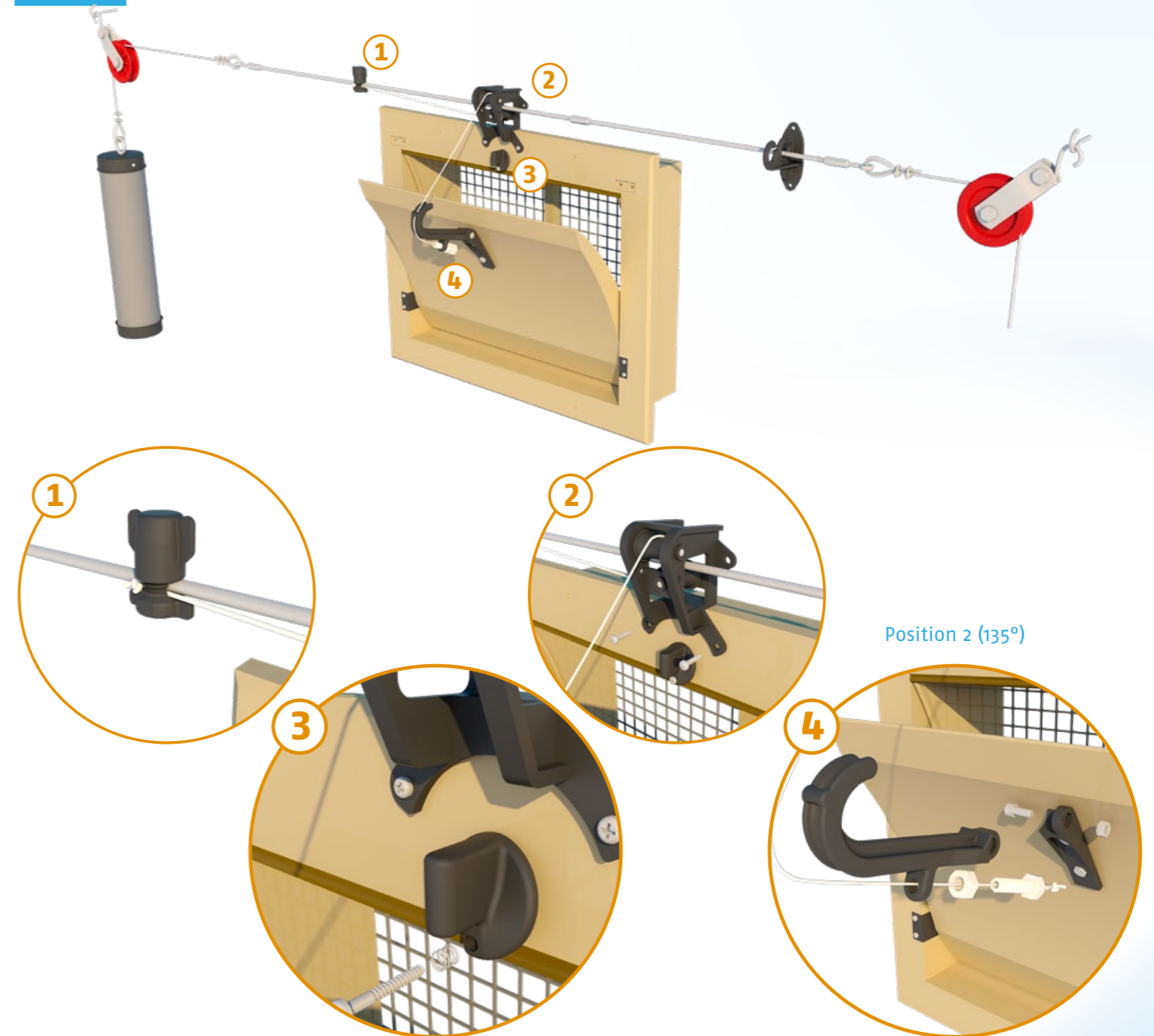

**DO'S & DON'TS**

**Make sure to mount inlets on a flat wall surface.**

A flat wall surface ensures optimal performance and, therefore, air leakage will be reduced to a minimum. For optimal functioning, ensure to caulk all the sides of the inlet with a silicon sealant.

**Do not use foams or fillers to fill space in between the inlet and the wall.**

Foams and fillers might cause damage to the inlet or cause it to jam as they have different expansion values due to temperature differences. When in doubt, please ask your supplier for additional information.

**For the set-up, connect the inlet to the main cable in closed position.**

Ensure the inlet is closed when connecting it to the main cable, as this will ensure that all of the inlets are connected in the same way and fewer adjustments are needed to optimize the set-up.

**Use screws with rivets for mounting the inlets into the wall and be careful with the polyurethane skin.**

With the use of rivets for mounting the inlets into the wall, you can prevent the screw from sinking into the flange or skin of the inlet. The outer skin of the polyurethane is hard, but the force exerted on the screws during installation might penetrate the skin.

**Cleaning**

Pay close attention while cleaning the inlets, avoid using corrosive cleaning solutions that might harm the polyurethane. Also make sure not to use too much pressure with the pressure washers as it might damage the skin of the inlets.

Use max. 1740 PSI at a minimal distance of 4" and temperatures not exceeding 120 F.